

ULTIMATE HIGH FIDELITY STEREO COMPONENTS

WUXMAN

R-3045

▶ OWNER'S MANUAL ◀

DUO-BETA CIRCUIT AM/FM STEREO TUNER-AMPLIFIER

CONTENTS

Switches & Controls	2 ~ 5
Installation	5 ~ 6
Connection Procedure	7
Block Diagram	8
Operation Procedure	9 ~ 10
Standard Curves	11 ~ 12
Specifications	13

WARNING: TO PREVENT FIRE OR SHOCK HAZARD
DO NOT EXPOSE THIS APPLIANCE TO
RAIN OR MOISTURE

DUE TO ADOPTION OF PIPE-CENTERED
HEAT SINK, PLACE THE R-3045 ALWAYS
IN HORIZONTAL, AS OTHERWISE HEAT
DISSIPATION BECOMES INSUFFICIENT TO
DAMAGE THE POWER TRANSISTORS.

Thank you for purchasing one of our quality products, the LUXMAN R-3045. With natural care, it will give you many years of outstanding performance and personal delight. Please read this Owner's Manual carefully before operating the unit, which gives detailed descriptions and operating procedures for the electronic and mechanical components of the R-3045. Again, thank you for your selection, and may "good listening" be your daily pleasure.

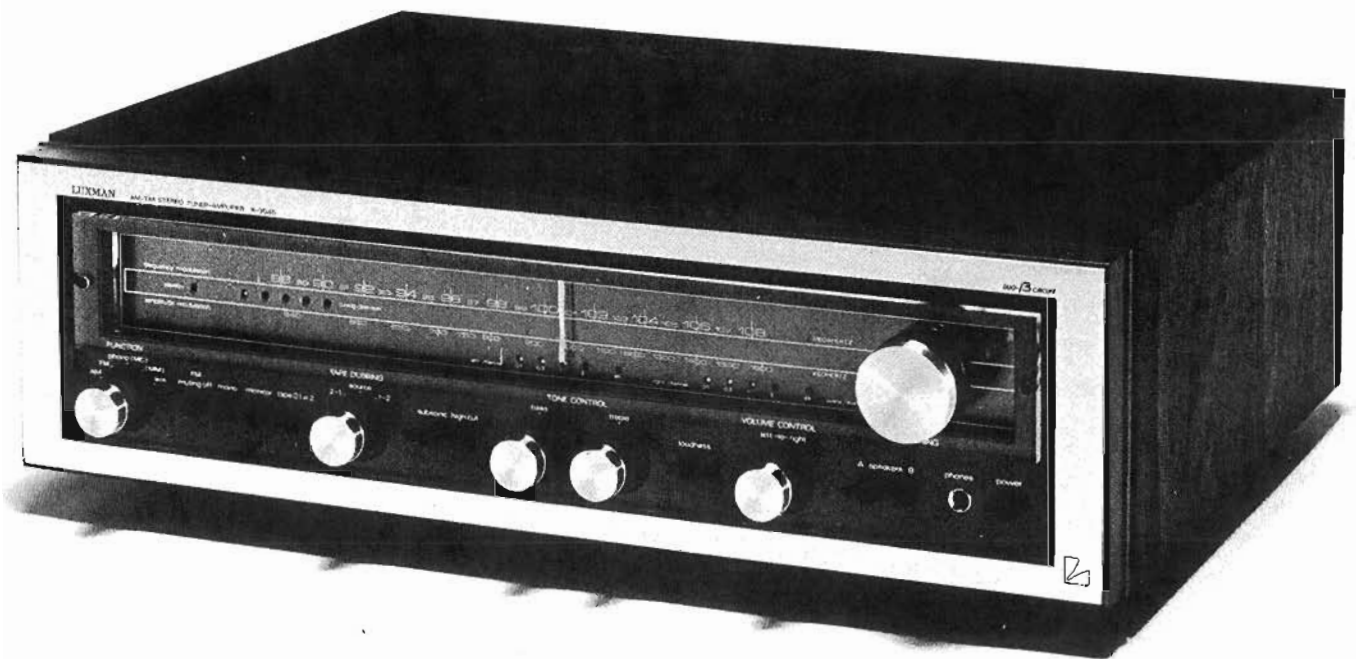



Switches & Controls

1. Input Selector Switch

This switch permits proper selection of desired program sources. You may set either of the positions provided (AM, FM, phono(MC), (MM), aux).

2. FM Muting Off Switch

Annoying interstation noise which is possible when tuning is shifted out of the exact tuning point can be eliminated by this switch in the case of FM reception. Keep this switch unpressed to remove interstation noises or other impracticably weak signals. Such FM signals as can be received in the "muting-on" position can be practised for stereo FM reception. It is recommended to set this switch always at the "protruded" position except when weak signals are received.

3. Mono Switch

This allows to select sound reproduction modes such as Stereophonic and Monaural. For further details refer to the "Mode Selection".

4. Tape Monitor Switch

When this switch is pressed in, tape playback is possible from the Monitor terminals. In the case of 3-head tape-recorder which has a playback head simultaneous playback monitoring is possible while recording. In this case this tuner-amplifier receives playback signals from the Monitor Terminals while feeding recording signals to the Rec. Out Terminals.

5. Tape Selector Switch

This switch allows to select tape playback terminals. When this is kept unpressed, tape playback is feasible from the TAPE-1 Monitor Terminal, while when pressed in, the Tape-2 Monitor Terminal is put into function.

6. Tape Dubbing Switch

The Tape dubbing switch is provided with 3 positions; in the center "source" position such program source as is selected by the Input Selector Switch is available for playback.

When the switch is set to the "1-2" position the output of tape recorder-1 is fed to the input of tape recorder-2 for reprinting, while the "2-1" position offers tape dubbing from "TAPE-2" to "TAPE-1". As this Dubbing Switch is independent of the signal path, you can enjoy playback of other program sources even during tape dubbing.

7. Subsonic Filter

When this switch is pressed in, the amount of low frequency range you hear is reduced at the rate of -6dB/oct. below 45 Hz. See the details in the "Operation of Subsonic Filter".

8. High Cut Filter

With this filter switch you can cut off the high frequency range above 7 KHz at the rate of -6dB/oct. See the details in the "Operation of High Cut Filter".

9. Bass Control

This is a level control of bass range. A clockwise turn of the

control boosts the bass response, and a counter-clockwise turn decreases it. This yields a flat frequency response when set at the rotation angle.

10. Treble Control

A clockwise turn of this knob boosts the treble response, while counter-clockwise turn decreases the treble level. This control is of the same construction as that of the Bass Tone Control.

11. Loudness Switch

When pressed in this switch, loudness control starts to function. This may be useful when you listen to music at low volume level. Refer to the details in the "Operation of Loudness".

12. Volume Control

A clockwise turn of this control increases volume, while a counter-clockwise turn decreases and finally cuts out volume. This is of dual concentric structure allowing separate control on the right and left channels. The front part is for the left channel, while the rear one is for the right. When the sound volume is balanced, sound is heard as if reproduced at the center of left and right speakers, with the Mono Switch set to the "depressed" position. Normally this tuner-amplifier is delivered from the factory well balanced in volume showing a straight concave line on the knob. See the further details in the "Volume Control".

13. Power Indicators

An instantaneous peak level of output power can be read on these LED indicators, which shows output power driven into 8 ohms load.

14. Speaker Selector Switch

This tuner-amplifier offers convenience to use 2 pairs of loudspeakers. You can choose independent or simultaneous driving of 1 or 2 systems. When the knob "A" is depressed, "A" speaker terminal starts to function, and likewise the "A" and "B" are pressed in, both "A" and "B" speaker terminals operate.

Note that the impedance of each speaker system should exceed 8 ohms when 2 pairs of speakers are simultaneously driven.

15. Tuning Direction Indicator

In the case of FM reception, this indicator shows the direction of tuning. When a broadcasting station is coming near, the indicator begins flashing. Turn the Tuning Knob slowly to the direction shown by the indicator, and the flashing ceases at a point where the precise tuning point is obtained. At this time, the Indicator shows the signal strength of the station just tuned in. When 3 or more indicators light up, stable reception in stereo mode is feasible.

Note that the indicator acts only as a signal strength indicator for AM reception.

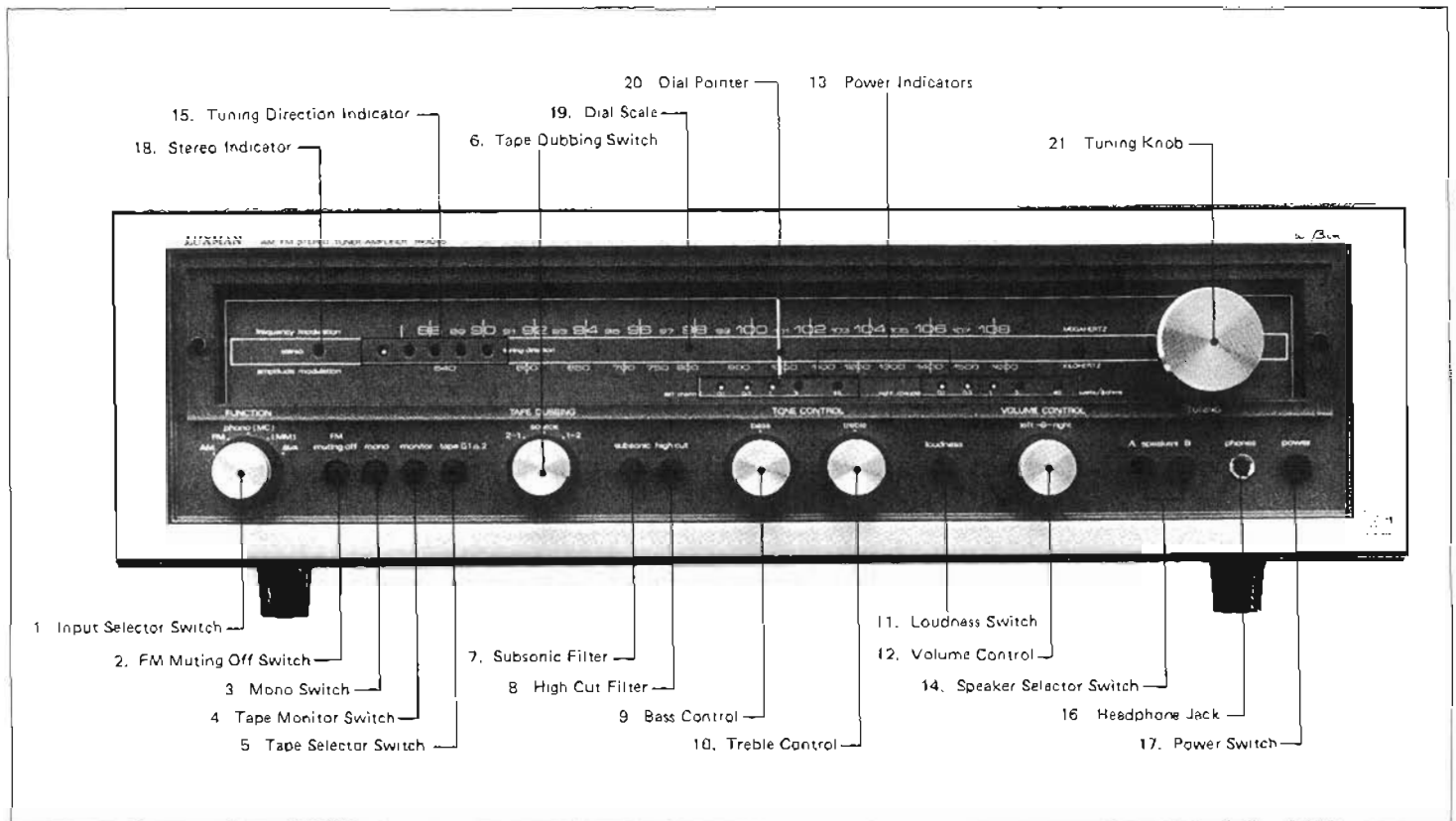

16. Headphone Jack

This is provided for private listening by stereo headphone. Output signals are always available irrespective of the position of the Speaker Selector Switch. For use of headphone, however, it is recommended to set both of the Speaker Switches to the "off" (protruded) position.

17. Power Switch

Repetition of pressing this knob ensures alternate switch-on and-off.

18. Stereo Indicator

When the Input Selector Switch is set to the "FM" position this Stereo Indicator lights up in case the FM stereo signals are being received, while it does not function against the mono signal. Further when mono FM on reception changes into stereo this lights up automatically to indicate stereo reception. On the contrary if receiving signals change from stereo to mono this indicator goes off. In case mono playback of stereo signals is desired, press in the Mono Switch.

19. Dial Scale

Turn the tuning knob according to the frequencies marked on this dial and the desired station can be received. Receivable frequency range for FM is from 88 MHz to 108 MHz, while for AM from 525 KHz to 1605 KHz.

20. Dial Pointer

The Dial Pointer is coupled to the Tuning Knob (21) to indicate receiving frequency. Read the frequency on the dial scale that is indicated by the dial pointer.

21. Tuning Knob

Use this knob to tune in your desired station.

22. AC Cord

For operation of this tuner-amplifier the AC plug should be connected to the AC power supply socket in your listening room.

23, 24. Speaker Terminals

Speaker systems are to be connected to these terminals. Loosen the terminal head and insert the speaker's bare cord to the terminal hole, then fasten it. Now firm connection is made. These terminals are coupled with the Speaker Selector Switch, which has to be selected properly. The terminal (23) is for the "A" speaker system and (24) is for the "B" system. Red terminal is for (+) while black for (-). For further details refer to the "Connection of Speakers".

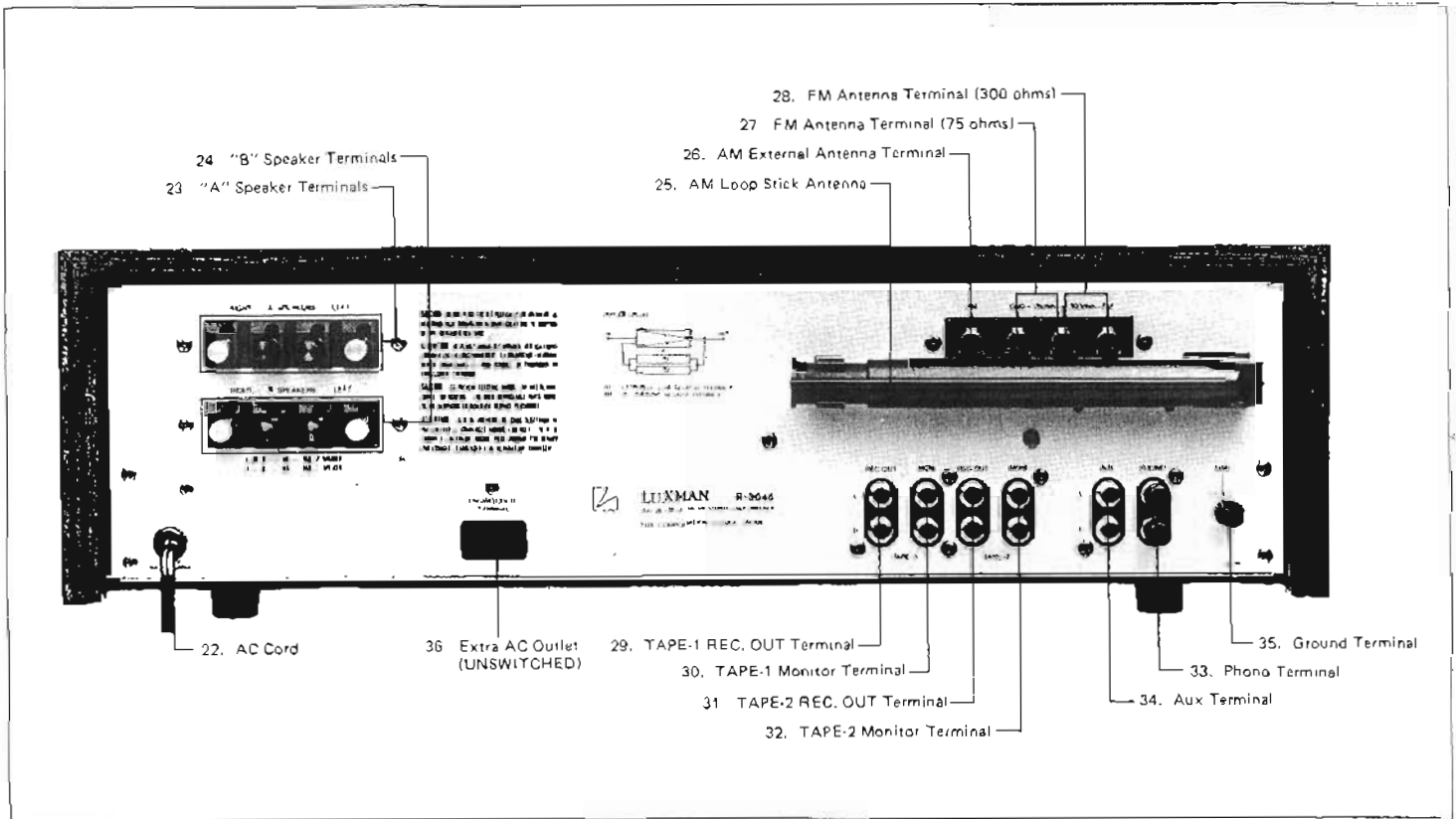

25. AM Loop Stick Antenna

Normally, good reception of AM broadcasting is possible with this antenna. Rotate this antenna to ensure the optimum reproduction.

26. AM External Antenna Terminal

In case normal reception is possible with the loop stick antenna, it is not necessary to use this terminal. But when reception of weak signals is desired, connect the exclusive outdoor antenna to this terminal. When simple wire antenna is used for this terminal, it is not always necessary to have a ground connection which sometimes deteriorates sensitivity. The exclusive outdoor antenna is effective to reduce undesired noises.

27. FM Antenna Terminal (75 ohms)

Use this connector for FM antenna with 75 ohms coaxial cable as lead-in wire. A coaxial cable can be easily connected — a core wire to the 75 ohms Terminal and the sheathing wire to the GND terminal.

28. FM Antenna Terminal (300 ohms)

Connect to this terminal a T type (di-pole) antenna or antenna feeder cable for TV (impedance 300 ohms) or FM antenna with TV feeder cable used as a lead-in wire. Do not use

short wire on this terminal in place of the antenna, and always connect the exclusive FM antenna.

29. TAPE-1 REC. OUT Terminal

Signal for recording is taken from this terminal, which is always available as long as an input signal is given to any of the Input Terminals (Phono, Aux, AM, FM) selected by the Input Selector Switch except when the Tape Dubbing Switch is set to the "2-1" position. In this case recording signals come from the TAPE-2 Terminal.

30. TAPE-1 Monitor Terminal

Playback of line-output of tape recorder is possible from this terminal. For playback through this terminal press in the Tape Monitor Switch, and set the Tape Selector Switch in the "protruded" position. A 3-head tape recorder makes it possible to monitor playback sound while recording

31. TAPE-2 REC. OUT Terminal

This terminal functions in the same way as the TAPE-1 REC. OUT Terminal. For playback through this terminal press in the Tape Monitor Switch. A 3-head tape recorder makes it possible to monitor playback sound while recording.

32. TAPE-2 Monitor Terminal

This terminal offers the same function as the TAPE-1 Monitor Terminal. For playback through this terminal press in both the Tape Monitor and Tape Selector Switches.

33. Phono Terminal

This input terminal functions in two ways according to the position of the Input Selector Switch. When the selector switch is in the "phono MM" position, you can connect the output of an MM-type cartridge. In this case the input sensitivity of this terminal is 2.2mV with impedance 45k ohms. While in the "phono MC" position, the phono equalizer stage is changed to produce higher gain, thus making it possible to connect a moving coil type cartridge to this terminal. In this case, the input impedance is 220 ohms with sensitivity 300 μ V.

34. Aux Terminal

This is an auxiliary input terminal for playback of such program source of flat frequency response as SW/LW tuner, line output of tape recorder, and audio output of TV receiver. Input sensitivity is 165 mV and input impedance 50 k ohms.

35. Ground Terminal

Connect the earth lead-wire of record player (from tonearm or motor). This terminal may be used as an earthing terminal of this tuner-amplifier, which is, however, not always necessary.

36. Extra AC Outlet (UNSWITCHED)

This outlet is convenient for supply of AC power to other annexed audio components such as record player, tape recorder etc. This terminal is independent of the Power Switch (17) of this tuner-amplifier where the AC power is always available. The maximum capacity of the terminal is 200W.



Installation

While the R-3045 Tuner-Amplifier has been designed for maximum ease of installation and operation, we strongly suggest you read this section through before proceeding to connect and operate the unit. Because the R-3045 incorporates many technical and operating refinements, it may be a bit different from equipment you have used in the past.

Placement and Mounting

The R-3045 may be placed in virtually any convenient location, keeping in mind the necessity of connecting cables to your speakers and an antenna for FM. Because of its advanced solid-state construction, the unit produces little heat. But certain minimum ventilation requirements are still necessary to provide optimum operation.

When the R-3045 is placed on an open shelf in a bookcase or cabinet (mounted in its integral metal case or with the accessory furniture case) about 10 cm (3") of free space should be allowed above it.

CAUTION:

The R-3045 employs most up-to-date heatloop type heat sink for more effective heat dissipation at the final output stage, and caution should be paid to its placement. Place the R-3045 always in horizontal, as otherwise heat dissipation becomes insufficient to damage the power transistors.

Antennas

Except in fringe areas no additional AM antenna is required with the R-3045. For FM, a folded dipole, available from your dealer, is generally adequate. This section will tell you how to connect them.

Installation

AM Antenna

In all but remote rural locations, the special ferrite core bar antenna mounted at the rear panel provides excellent AM reception. For the best results, select the optimum location against the direction of the transmission. If an external antenna is required, connect a length of wire (any type will do) to the AM ANTENNA terminal on the rear panel.

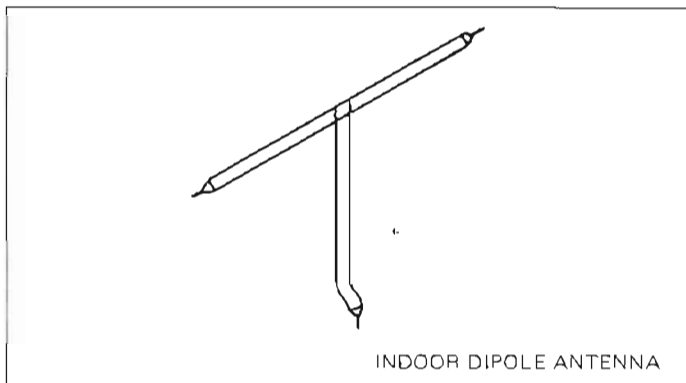

FM Antenna

Connect the antenna lugs to the 300-ohm ANTENNA terminals on the rear panel. Rotation of the FM antenna will be needed for the best reception.

FM Outside Antenna

If you live in remote fringe area, or in a metropolitan area with reception problems, it may be necessary to use an outside antenna. If you require a separate FM antenna, purchase a quality FM unit from your dealer. Connect the cable from the antenna to the 300-ohm ANTENNA terminals on the rear of the R-3045.

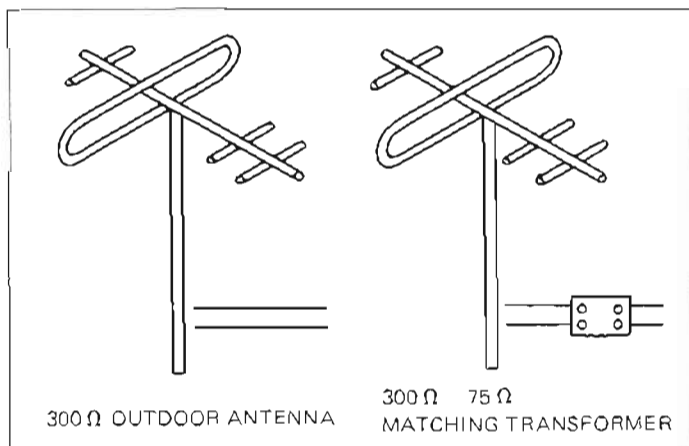

Master Antenna and Other 75-ohm Systems

Some buildings have master antenna that carry FM. Connect to the 75-ohm ANTENNA terminal on the rear of the unit.

NOTE: For clarification, if necessary, see your dealer, who can advise you concerning the best antenna installations.

Speakers

Connecting Speakers

Look at your speakers. You will note that one terminal is unmarked. The other will be designated 'COM', 'COMMON', 'GND', 'GROUND', or Black. Connect the 'COM' terminal of each speaker to the appropriate black SPEAKERS terminal on the rear of the tuner-amplifier. Make sure the wire does not contact the chassis or another terminal, to prevent shorts. Then connect the other speaker terminal to the appropriate red SPEAKERS terminal of the tuner-amplifier. To connect a single pair of speakers, connect the wires from the left speaker (as viewed from the listening position) to the "L" A SPEAKERS terminals. Similarly, connect the right speaker to the "R" A SPEAKERS terminals of the tuner-amplifier. The 2nd pair of speakers can be connected similarly to B SPEAKERS terminals.

Speaker Phasing

To enjoy good stereo reproduction, it is necessary that the two stereo speakers in any location work as a team, 'pushing' and 'pulling' the air in unison. If this work is incomplete, low-pitched sounds will sound weaker than they should, and the stereo effect at higher frequencies will become indistinct. To connect your speakers for proper stereo effect (this is called "phasing"), proceed as follows.

Play an FM program with the Mono Switch in the "depressed" (mono) position. If the low bass notes sound normal, the speakers are properly phased. If they sound thin, or weak, the speakers are out of phase. Should this occur, turn off the unit and carefully check the connections at either one of the speaker.

Tape Recorders-Decks

Tape Recorders and Decks

Two tape recorders can be connected to record and playback through the R-3045. See page (9) for tape connections of all types. For additional information see the manual of your tape machine or consult your dealer.



Connection Procedure

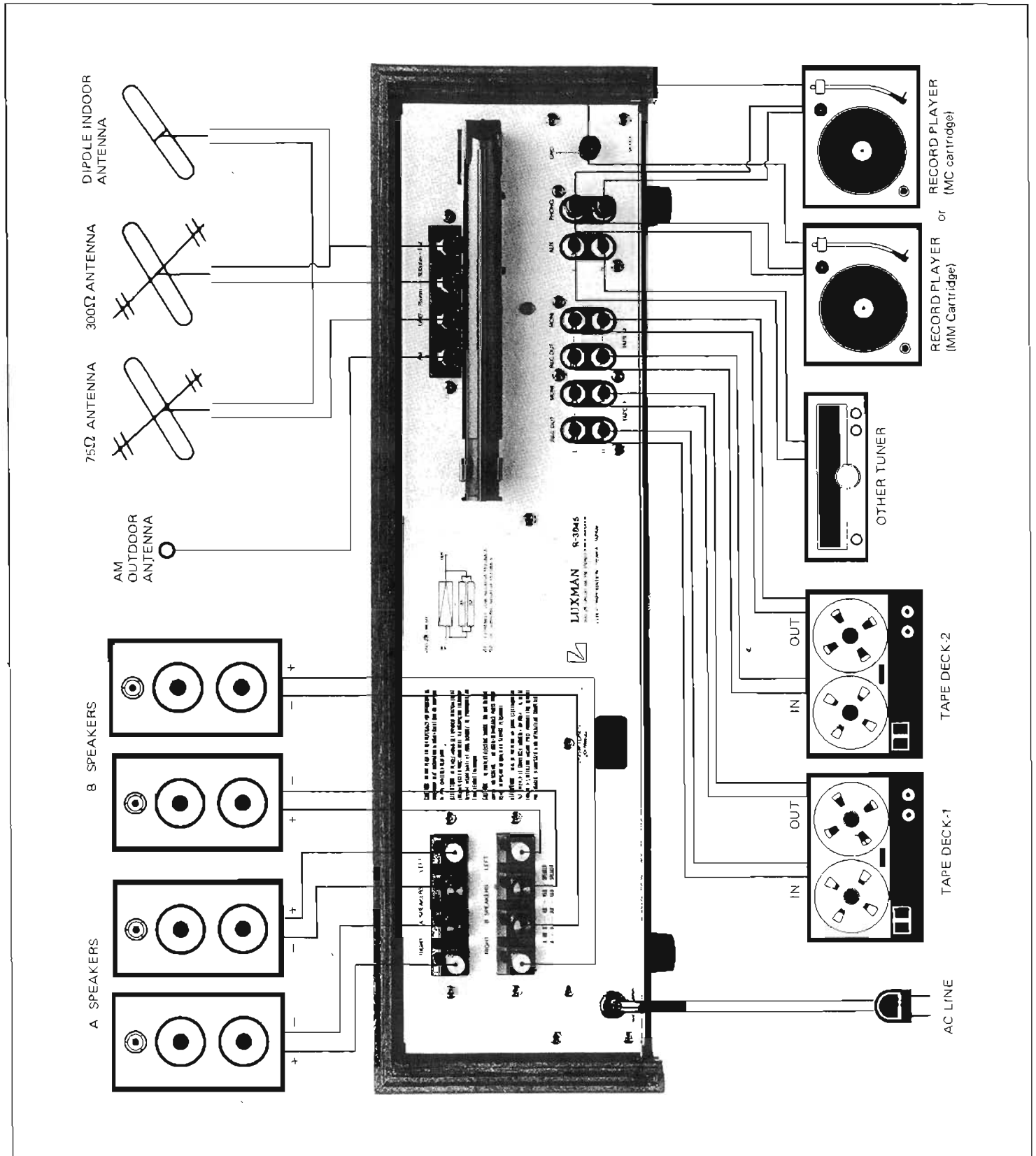



Block Diagram

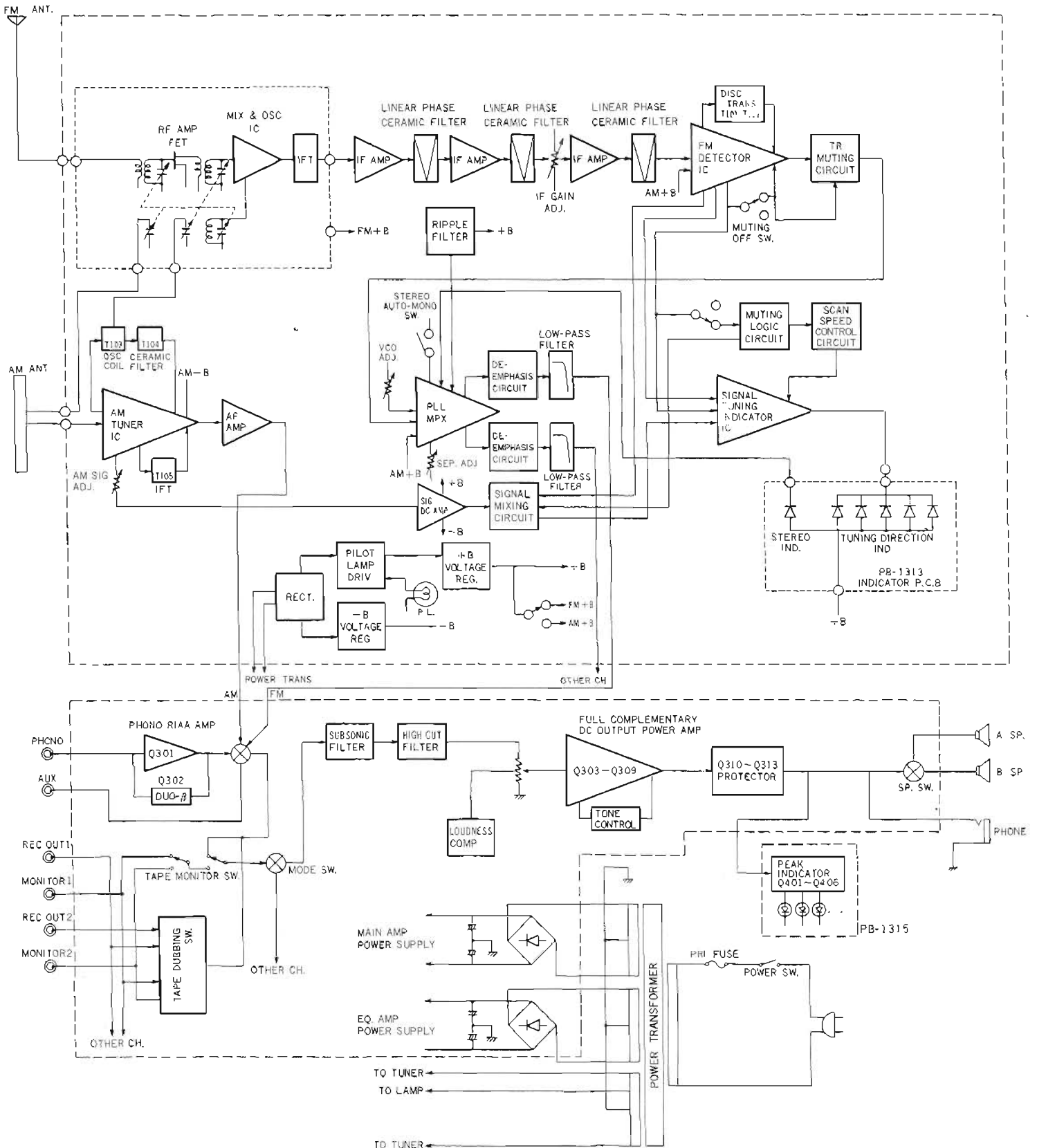



Operation Procedure

Playback from Record Disc

Playback From Record Disc

Put a disc on the turntable for playback performance. As the volume control is turned clockwise from the cut position, playback sound comes out from speakers. The sound playback is possible regardless of the position of Mode Selector etc. as far as these essential controls are set to the correct position such as Input Selector Switch (1), Tape Monitor Switch (4), Speaker Selector Switch (14) and Volume Control (12). Now all preparations have been completed. Check if the volume levels on both right and left speakers are identical. If deviated adjust it by the Volume (Balance) Control. For stereophonic playback see to it that the Mono Switch is kept in the "unpressed" position, as otherwise correct stereophonic playback is not feasible.

Playback of AM/FM Broadcasting Program

Selection of the input selector (1) to the AM or FM position ensures playback of AM or FM broadcasting program. If you want you can connect other tuner (AM, FM, LW or SW etc.) to the AUX terminal of this tuner-amplifier. In this case the selector must be set to the corresponding position. Both for FM stereophonic and monaural broadcasting the Mono Switch can be set to the "FM" position, for such accommodation to the input source can be made in the tuner section. In case weak FM stereo is received and you feel it noisy, set the Mono Switch (3) to the "pressed" position for better reproduction. In case of AM/LW program from other tuner there is possible trouble of modulation hum, which can be eliminated by varying the distance and angle of these components.

Other Playback

The signals of flat frequency response from such sources as TV receivers do not need an equalizer stage, and for playback of such audio equipments the AUX terminal can be used. connection and operation is same with that of AM/FM broadcasting program.

Playback from Tape

Playback from Tape Monitor Terminals

Almost all of tape-recorders, and tape-decks currently marketed integrate audio pre-amplifiers in their circuit. Also there is a tape-player exclusively for playback. Connect the output terminal (LINE OUT) to either of the two Tape Monitor Terminals (30) (32). Then press in the Monitor Switch after selecting the Tape Selector and the playback from the Monitor Terminal is realized. This amplifier section can be divided into 2 sections — one before the Recording Output Terminals (REC. OUT) and the other after the Tape Monitor Switch, and 3-head tape-recorder makes it feasible to make recording with the former section and simultaneously to make playback with the latter section.

Playback from Aux Terminals

Playback of tape is possible if the line output of tape recorder or tape-deck is connected to the AUX terminal of this tuner-amplifier by use of pin-jack lead and the Input Selector Switch is set at the "aux" position. Note that when tape playback is made through AUX terminals, the line input or AUX input terminals of the tape-recorder should not be connected. If connected to the Recording Output Terminals (REC. OUT) of the tuner-amplifier there may be possible oscillation by feed-back of signals.

Recording on Tape

In case of playback of various program sources through input terminals of this tuner-amplifier, the same signals to those reproduced in speakers are available at the Recording Output Terminals (29) (31). By connection of these terminals to the input terminals (AUX or LINE-IN) of the tape recorder you can enjoy simultaneous recording and playback. These recording signals are taken before the Tape Monitor Switch and there is no influence of such controls as Volume Controls, Tone Controls and Filters etc.

Simultaneous Playback Monitoring

A 3-head tape-recorder ensures Simultaneous Playback Monitoring enabling to ascertain perfect recording. In case of 3-head tape-recorder, heads and amplifiers for recording and playback exist independently in the circuit which ensures simultaneous recording on tape and playback of the sound recorded on the tape.

In this case recording on tape and playback of the recorded sound is practised at the same time, and connection must be made for both functions. Need to connect the Recording Output Terminal (29) or (31) to the Line Input Terminals (AUX Input) of tape-recorder, and the Tape Monitor Terminal (30) or (32) to the Output Terminals (LINE OUT) of a tape-recorder. Now repetition of pressing the Monitor Switch makes it feasible to compare the original sound with recorded one.

Thus possible recording error can be prevented in case of 3-head tape-recorder. Incidentally note that reproduction of recorded sound becomes a little-bit delayed as compared with that of original sound since there is a gap between recording head and playback head.

Tape Dubbing (Reprinting)

So called tape dubbing (tape-to-tape reprinting) is possible with the Tape Dubbing Switch (6), when the switch is set to the "1-2" or "2-1" position. In the "1-2" position connect the LINE-OUT terminals of the tape-recorder with recorded tape to the TAPE-1 MONITOR (30) while the LINE-IN (AUX) terminals of the second tape-recorder to the TAPE-2 REC. OUT Terminal (31), and the tape dubbing is possible from the 1st to 2nd tape-recorder. vice versa in the "2-1" position.

In the dubbing process if the LINE-IN terminals of the 1st tape-recorder is connected to the "TAPE-1 REC. OUT", and

Operation Procedure

the LINE-OUT of the 2nd tape-recorder to the TAPE-2 MONITOR Terminal (32), simple operation of the Input Selector Switch between "tape-1" and "tape-2" allows comparison between the original sound and newly recorded one.

Simultaneous Recording

The R-3045 is provided with 2 sets of Recording Output Terminal (REC. OUT) enabling to record simultaneously on 2 tape-recorders. If desired, combination recording on reel-to-reel recorders and/or cassette recorders can be enjoyed. Remember that the Dubbing Switch should neither be set to the "1-2" nor "2-1" position.

This facility is useful for safer printing or effective recording etc. As the impedance at the Recording Output Terminals is kept sufficiently low, mutual interference will be almost nil between the recorders under simultaneous operation.

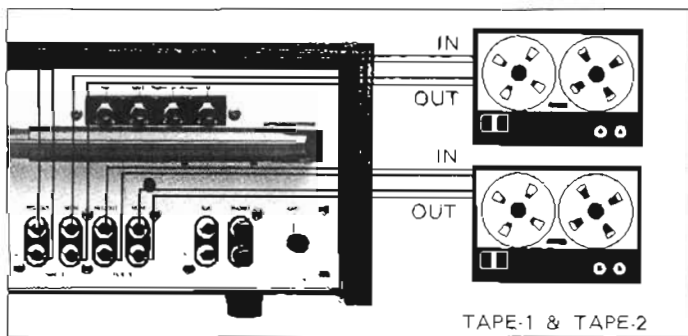

Operation of Controls

Selection of Mode

This tuner-amplifier is for stereophonic reproduction and integrates independent amplifiers for 2 channels (right and left). The Mono Switch is placed between these 2 amplifiers to change the mode of reproduction.

knob position	connection		performance	use
	input	output		
STEREO (unpressed)	R → R L → L	R L	normal stereo playback	for normal stereo playback
MONO (pressed)	R → R L → L	R L	right and left input signals are integrated	for monaural playback of stereo program

Volume Control

Sound volume can be properly adjusted by volume control. In the attenuation characteristics turning angle is proportionate to attenuation degree of dB, and the dB value and the volume audible to human ears are in the proportionate relation. That is to say, the rotation of knob is in proportion to the sound volume felt by human ears. The increasing degree of volume is felt quite natural as the knob is turned on to the clockwise direction.

This is of dual concentric structure and allows separate con-

trol on both right and left channels. The front knob varies the left channel volume, while the rear one controls the right volume.

In case of deviation between the volume levels of right and left channels, adjust unbalanced volume level by 2 knobs. The volume balance of both channels can be adjusted so that monaural disc sound reproduced by the stereo cartridge comes from the center of the right and left channels. Usually the volume level of both channels is adjusted identical at the straight engraved line on the knob.

Thus, a proper balance is established through all playback stages. If a program source is unbalanced for the speakers are placed in an oblique position), establish the correct balance with this control.

Tone Controls

The ultimate purpose of the audio system is to make the high fidelity reproduction of program sources. The reproduction conditions and circumstances do not always match with recording conditions, and it is impossible to reproduce the same sound with the original one.

Also there is no objective standard to judge good sound from inferior one. The only possible solution is for every listener to create his favorite sound according to his own taste. It is therefore very important that the audio system offers such facility to permit flexible controls for creation of the best sound. This tuner-amplifier is equipped with various tone controls for subtle and minute control of the reproduced sound such as Bass Control (9) and Treble Control (10).

Bass Control is a tone control on frequency response of low frequency range. It is designed so that response is flat at the electric center point, and a clockwise turn of the knob intensifies low frequency range while counter-clockwise turn yields attenuation.

Treble Control is a tone control on frequency response of treble frequency range. It is designed so that response is flat at the electric center point, and a clockwise turn of the knob intensifies high frequency range while counter-clockwise turn yields attenuation.

Operation of Subsonic Filter

When this filter is switched on the amount of low frequencies you hear is reduced at the attenuation rate of 6dB/oct below 45Hz. Useful for removal of low frequency noise such as rumbling of phono motor. Also this can be used as an auxiliary control for Bass Control.

Operation of Loudness Switch

Because loudspeakers and ears generally respond less to extreme high and low (treble and bass) frequencies as volume levels are reduced, the LOUDNESS switch is included to boost these frequencies and thereby provides tonal compensation. Whether or not you use this switch depends upon the levels at which you generally listen, the kind of speakers you have, the room acoustics and a number of other variables. Experimentation is the best guide to using the LOUDNESS switch.



Standard Curves

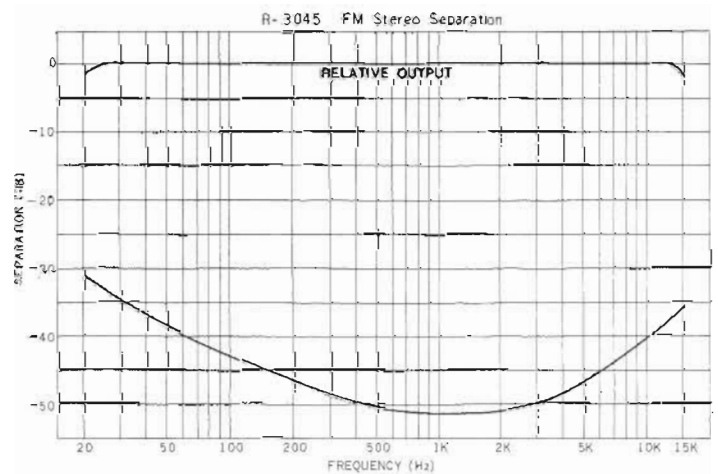
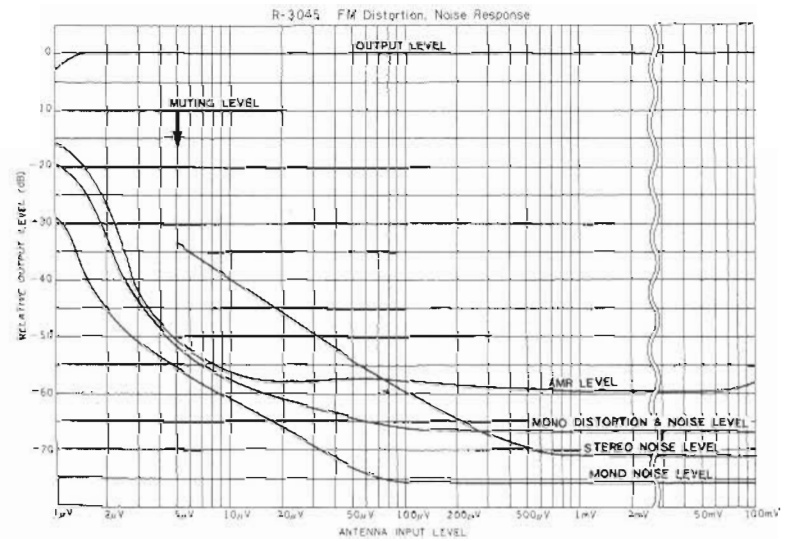
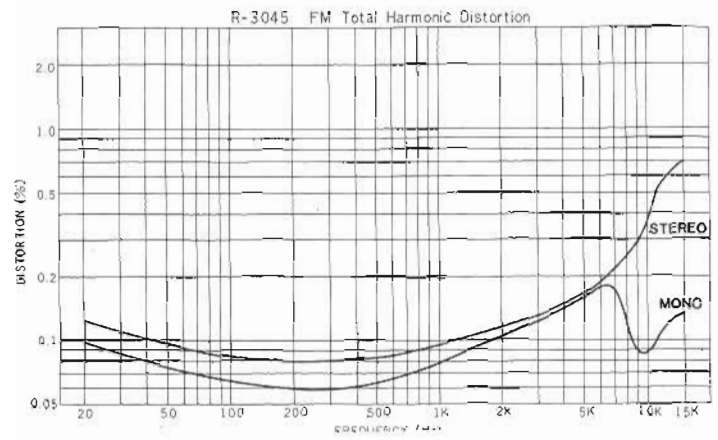
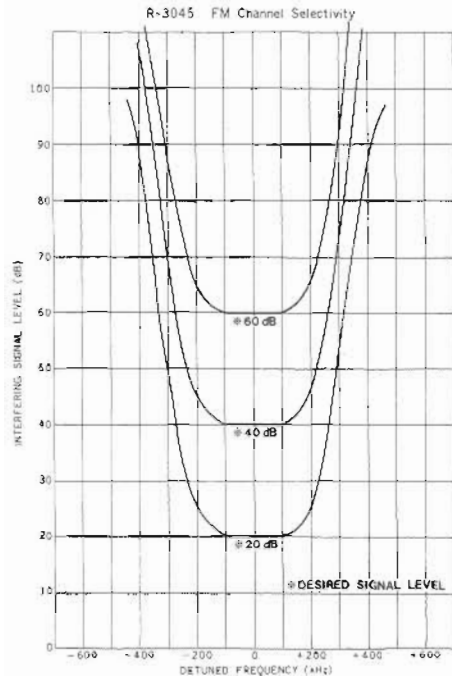

Standard Curves

R-3045 I.M. Distortion vs. Power
 Input : Aux, Output : 8Ω Load Both CH Driven, Volume : Max
 Tone : Flat, Frequency : 60Hz : 7kHz = 4 : 1

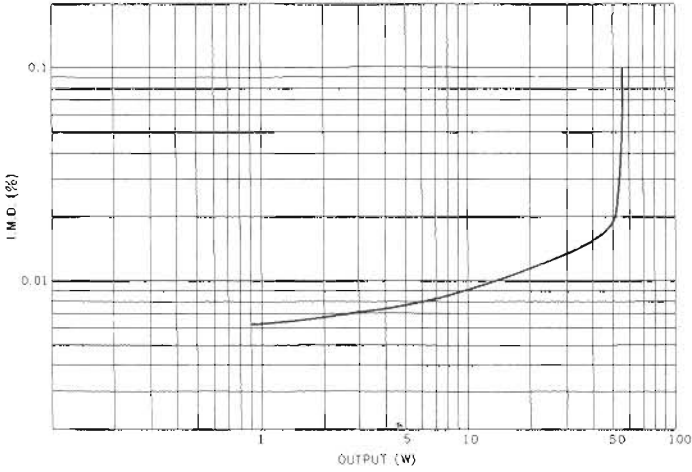

R-3045 T.H. Distortion vs. Power
 Input : Aux, Output : 8Ω Load Both CH Driven
 Volume : Max, Tone : Flat

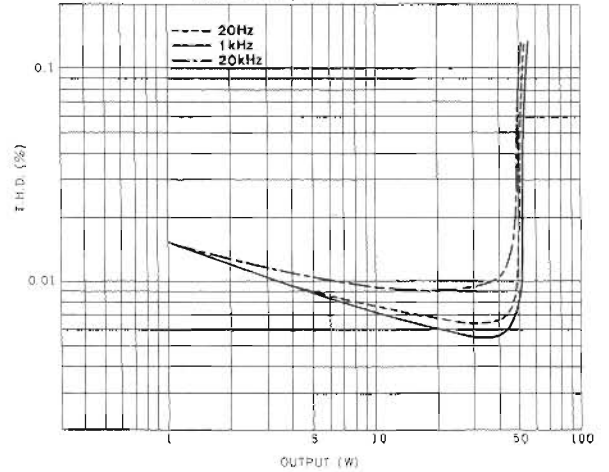

R-3045 Filter
 Input : Aux, Output 8Ω Load, Tone Control : Flat

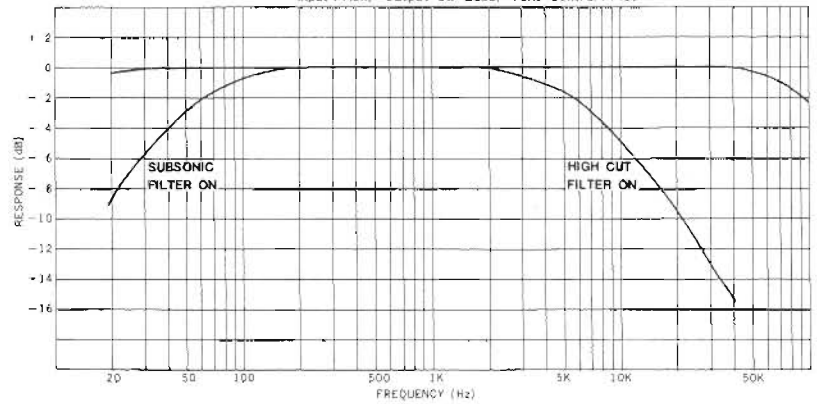

R-3045 Tone Control
 Input : Aux, Output 8Ω Load, Filter : Off

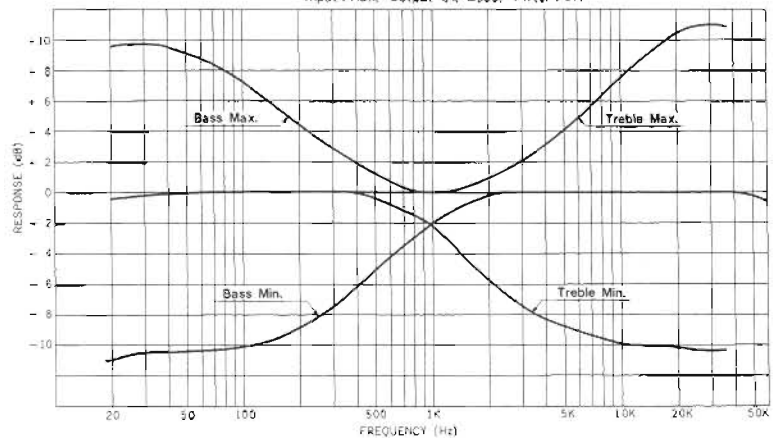



Specifications

[AUDIO SECTION]

Power Output	45Watts minimum continuous per channel both channels driven into 8 ohms load at any frequency from 20 Hz to 20,000Hz with no more than 0.05% total harmonic distortion.
Rated I.M.	no more than 0.05% (8 ohms, 45W/ch. both ch driven, 60Hz : 7kHz = 4 . 1)
Frequency Response	15 Hz ~ 60 kHz (± 1 dB)
Input Sensitivity	2.2 mV (phono MM), 0.3 mV (phono MC) 165 mV (aux. moni)
Phono Overload	160 mV (at 1 kHz)
Signal to Noise Ratio	90 dB (phono MM, IHF-A weighted, 10 mV) 98 dB (aux, monitor IHF-A weighted)
Residual Noise	no more than 0.5 mV
Tone Control	Treble, $+7$ dB at 10 kHz -10 dB at 10 kHz Bass, $+7$ dB at 100 Hz -10 dB at 100 Hz
Filters	Subsonic 45 Hz (6dB/oct) High cut 7 kHz (6dB/oct)
Crosstalk	70 dB (aux, monitor at 1 kHz)
Loudness Control	+10 dB at 100 Hz, +8 dB at 10 kHz (VR: -30 dB)
Peak Indicator	0.1, 0.3, 1, 3, 45W

[FM SECTION] (IEEE/IHF Standard)

	(MONO)	(STEREO)
Usable Sensitivity	1.9 μ V (10.8 dBf)	
50 dB Quieting Sens. (75 μ Sec.):	3.1 μ V (15.0 dBf)	
Signal to Noise Ratio at 65 dBf	75 dB	
Muting Threshold:	5 μ V	
Frequency Response:	± 1 dB (30 ~ 15000 Hz)	
Distortion at 65 dBf		
100 Hz	0.1%	0.2%
1 kHz	0.1%	0.15%
6 kHz	0.2%	0.3%
Capture Ratio at 65 dBf:	1.3 dB	
Image Response Ratio:	55 dB	
IF Response Ratio	90 dB	
AM Suppression Ratio:	55 dB	
Stereo Separation:		
100 Hz		40 dB
1 kHz		45 dB
10 kHz		38 dB
Spurious Response Ratio:	80 dB	
Alternate Channel Selectivity		
± 400 kHz:	65 dB	
SCA Rejection Ratio:	60 dB	
Adjacent Ch. Selectivity		
± 200 kHz:	5 dB	

[AM SECTION]

IHF Usable Sensitivity at 1 MHz.	220 μ V/m
Image Response Ratio at 1 MHz	50 dB
IF Response Ratio at 1 MHz.	40 dB
Distortion.	0.5%

[GENERAL]

Power Consumption:	120V 2.5A
Dimensions.	500(W) x 315(D) x 165(H) mm (19-11/16" x 12-13/32" x 6-1/2")
Weight:	Net 10.5 kgs (23.1 lbs.) Gross 12.0 kgs (26.4 lbs.)

Specifications and appearance design subject to change without notice.



LUX CORPORATION, JAPAN

1-1, 1-CHOME, SHINSENRI-NISHIMACHI, TOYONAKA-SHI, OSAKA 565
PHONE 06-834-2222 CABLE LUXMAN TOYONAKA TELEX: J 63694

LUX AUDIO OF AMERICA, LTD.

160 DUPONT STREET, PLAINVIEW, NEW YORK, N.Y. 11803, U.S.A